

# MonaAir

*Technology At The Service Of Your Air*



## NATURAL SOLUTIONS

FOR AIR TREATMENT AND DISINFECTION

[www.MonaAir.com](http://www.MonaAir.com)





# MonaAir

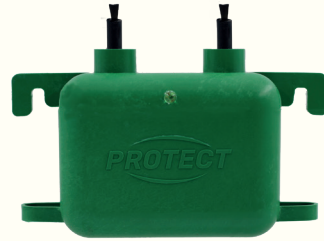

**DEFENDER 7**

**PROTECT**

Enjoy your **indoor spaces** while breathing **clean air**. The unique design of **our professional air purifiers** allows for the reproduction of **ionization**, a **natural phenomenon** that **purifies the air and enhances your daily life**.



# PRECISE AND EFFECTIVE AIR DISINFECTION

Our devices **cleanse the air and the surface**. They act on particles invisible to the naked eye, loaded with various types of pollution.



Certificate  
MonaAir issued  
at installation\*



## FILTERING\*

Our devices are equipped with **technologies that filter dust, pollen, spores, and molds**. This system **enhances the performance** of the existing filters in the ventilation system.



## PURIFY\*

**MonaAir** modules make it possible to **neutralize indoor air pollutants**, including **Volatile Organic Compounds (VOCs)** such as **household products, exhaust fumes, and odors** (body odors, cooking smells, tobacco, etc.).

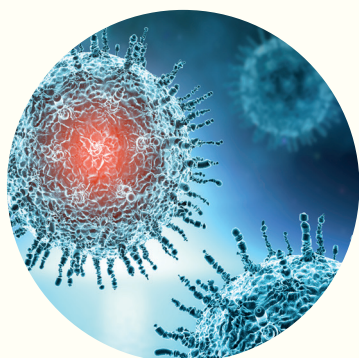

## INACTIVATION\*

**UV technology and cold plasma** target **bacteria, viruses** (Staphylococcus aureus, gastro, cold, flu, COVID-19...) and **fungi** (the spores responsible for mold) in order to **eliminate them in the air and on surfaces**.

\* Certificate issued upon installation of a MonaAir module "Air purified by MonaAir guaranteeing air treatment": with the above information.



# WHY IS IT IMPORTANT TO CLEANSE THE AIR IN OUR ROOMS ?

We spend 70-90% of our time indoors and the contaminated air is 5 to 9 times more concentrated in an enclosed space.\*

Exposure to **poor air quality** has a **significant impact on our health**, causing **9 million premature deaths per year worldwide**.\* Air pollution is caused by human activity and reduces life expectancy by **2.9 years**.\*

The most vulnerable people to this pollution are **pregnant women, children and babies**, the **elderly**, and « **sensitive** » individuals (such as those with allergies or asthma).

**Improving indoor air quality** reduces the **risk of developing diseases, chronic fatigue, and allergies**, while also promoting **concentration and well-being**.

**Our air purification modules** are designed **without chemical agents**, using technologies that reproduce **natural phenomena** for improved air quality.

We spend  
**70 to 90 %**  
of our time indoors

Air pollution  
**5 to 9**  
times more  
concentrated indoors

**65%**  
of systems do not  
provide adequate air  
exchange.

**10%**  
of buildings are  
infected with  
pathogenic bacteria.

\* «Les chiffres de la Pollution de l'air intérieur», writer Murprotec, source ADEME.

\*\* «Pollution and Health» article written by The pollution and health Commission, journal The Lancet, june 2022.

\*\*\* «La Pollution de l'air tue plus que le tabac, les guerres ou le sida, selon cette étude» article HuffPost, march 2020.

# WHERE DOES INDOOR POLLUTION COME FROM ?

Indoor pollution is caused by the use of products that are **harmful to health** during our daily activities. Our devices **help reducing this pollution** by promoting **healthy ventilation** and maintaining a **clean and dry environment**.



## OUR LIFESTYLE HABITS

Indoor pollution is caused, among other things, by the combustion of fuels for heating and cooking, the vaporization of chemicals for cleaning and decoration, the chemicals emitted by furniture, flooring, paint, adhesives, cosmetics, scented candles, and even pets. Sources of indoor pollution also include radon, mold, and bacteria.



## HOME DECOR AND FURNISHINGS

Elements such as paint, wall coverings, varnishes, glued wood furniture, and carpets can emit VOCs (Volatile Organic Compounds) that can be hazardous to health, especially when new.

Prolonged exposure to these substances can have adverse health effects, such as headaches, eye, nose and throat irritations, stomach pains, dizziness, and in severe cases, respiratory and cardiovascular problems.

## SOURCES OF INDOOR AIR POLLUTION



## PETS, PLANTS

Pets and plants can also contribute to indoor pollution by emitting allergens. The use of treatments can also cause pesticide pollution.



# WHAT ARE THE EFFECTS OBSERVED ON A DAILY BASIS ?

The possible effects are **numerous**, both on **health** and on the **perception in buildings**. Indeed, indoor pollution can promote, among other things, the **appearance of bad smells**.

Indoor pollution can affect air quality by producing **unpleasant and potentially harmful odors**. This is due to the presence of **chemicals in the air** that can be detected by our senses.\*

A study of 1000 people found that **30% of individuals experienced health problems** when exposed to **scented products in the workplace**, **20% would quickly leave a company** due to air freshener odors, and **50%** prefer hotels, healthcare facilities, and airplanes to be **odor-free**.\*

Sources of pollution are **multiple** but can be **eliminated with an air purifier**. Our natural and effective purification technology **helps restore clean, fragrance-free indoor air**.

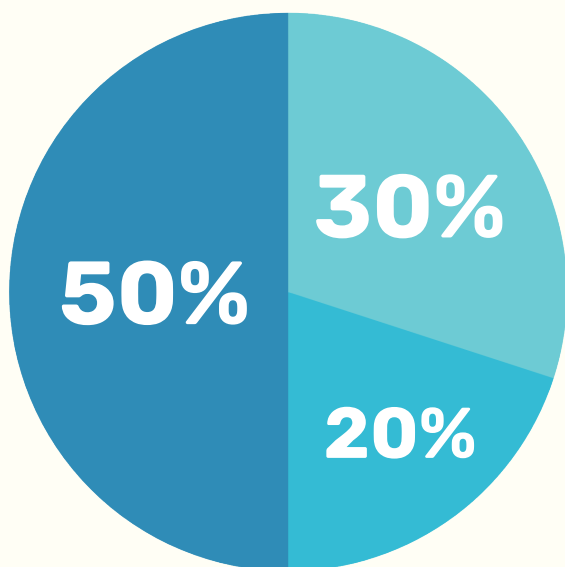

\* « Est-ce-qu'un purificateur d'air est efficace contre les odeurs ? », [air-purificateur.com](http://air-purificateur.com)



## FUNCTIONING OF THE MODULE.

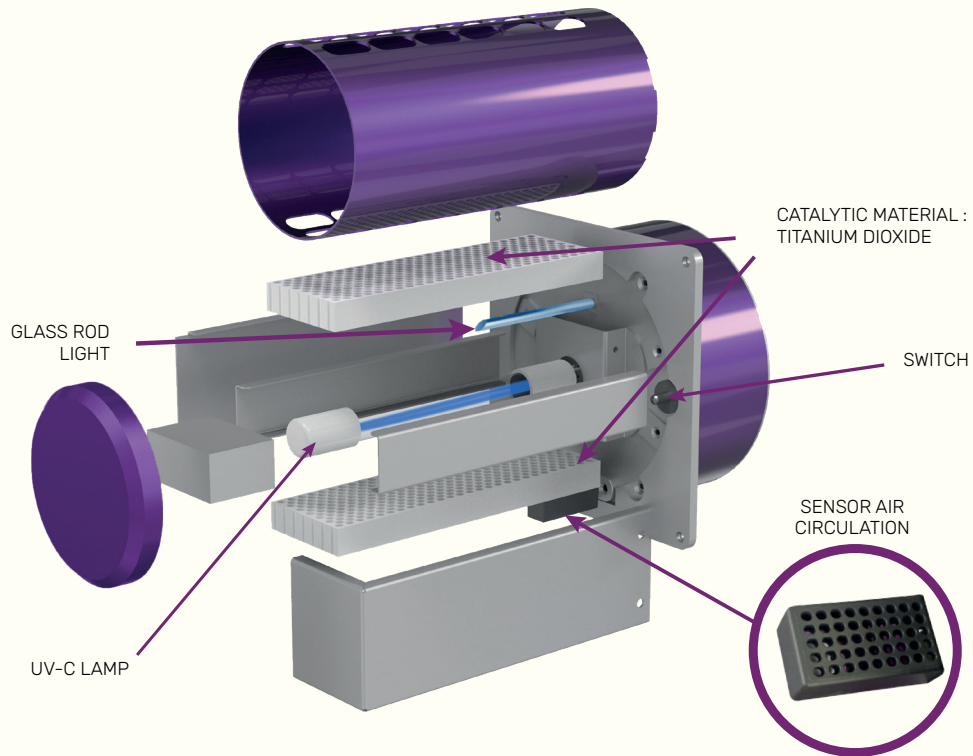

## THE TECHNOLOGY

The technology used by the **Defender<sup>7</sup>** combines the **UV-C lamp** and the **catalytic material**. These two elements produce a **chemical reaction called Photocatalytic Oxidation**.



The **UV-C rays** from the lamp come **into contact with the TiO<sub>2</sub> (Titanium Dioxide) catalyst sprayed on the honeycomb support**, which causes the **release of electrons (e<sup>-</sup>)**.

The latter, naturally wishing to recombine as quickly as possible, will use **the oxygen and water, present in the air, to form molecules of hydrogen peroxide (H<sub>2</sub>O<sub>2</sub>)**.

Upon their creation, these molecules will in turn react with **UV-C rays and break down** to form **oxidizing ions**. Very reactive, the latter will **ionize the undesirable molecules**, in order to make them lose their properties. **The air is thus purified.**

### SAFETY

The UV-C lamp integrated in the module does not expose to UV rays. The Defender<sup>7</sup> is designed to be harmless to users and to preserve the environment.



# MODULE INSTALLATION

Thanks to this new concept, the **Defender<sup>7</sup>** device is **compact and ergonomic**. It adapts easily to **all ducted air conditioning systems** and **all double flow VMC installations**. The device treats the return of air from the ventilation ducts. Thus, the module will be in direct contact with the air flow.

Once the air is disinfected in the **Defender<sup>7</sup>** device, it is distributed to all the ducts. Thanks to **the air circulation sensor**, the module **switches on and**

**off only when the ventilation is working**. This system increases the life of the UV-C lamp.

**How to install a Defender<sup>7</sup> device ?** Unlike the conventional system which is more restrictive (deadlines, cost, maintenance and labor) **the installation** of a module is **quick and easy to use**. **The module is installed on the existing ventilation system by placing it on the ventilation duct.**

**A simple 3-step operation** allows the installation **INSTALLATION DEFENDER<sup>7</sup>**

## CONVENTIONAL INSTALLATION

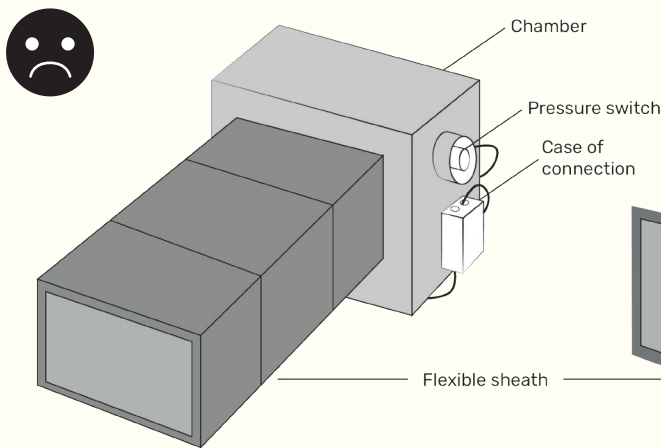

## INSTALLATION DEFENDER<sup>7</sup>

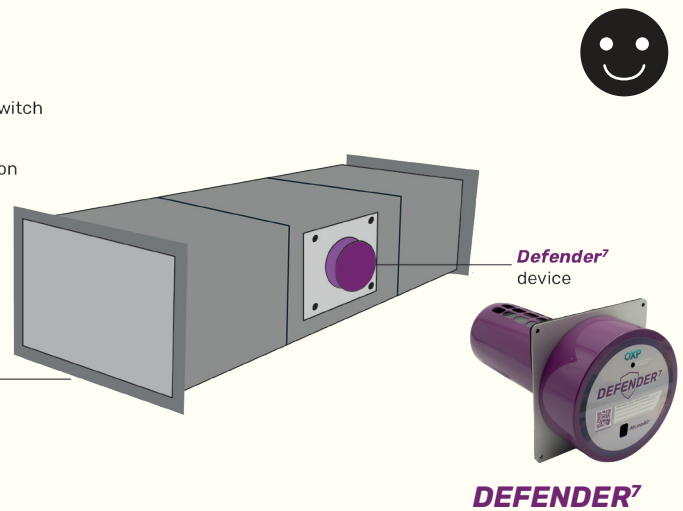

# ALL IN ONE

of the device, which once connected to the power supply, will offer you clean and disinfected air thanks to the **Defender<sup>7</sup>**.

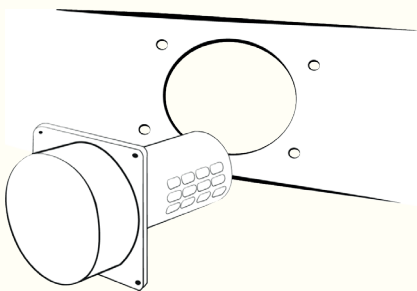

Make the holes in the duct to install the fixing plate.

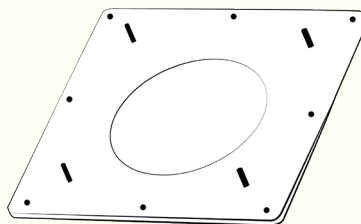

Screw the plate and the module.

220  
Volt



Connect the module to the power supply.

## MAINTENANCE

For optimal use, it is recommended to change the UV lamp every 12 months.





# DEFENDER 7

Purifies your air



Speed range	2-7 m/s
Range of use	1500 to 2000m <sup>3</sup> /h
Purifying area	130m <sup>2</sup> (if regulatory flow of 15m <sup>3</sup> /hrs/m <sup>2</sup> )
Dimensions (BxHxØ)	25 cm x 15 cm x 9 cm
Minimum depth installation	20 cm
Weight	1,05 kg
Power supply	220-230V
Power	11 W
Optimal temperature of use	45°C
IP	IP44 (For the front side of the product)
Bacteria*	Staphylococcus Aureus
Minimum humidity level required	20% HR
Warranty	2 years
Comes with	<ul style="list-style-type: none"> <li>- 1 user manual</li> <li>- 1 power cable (1m70)</li> <li>- 1 fixing plate</li> <li>- 4 wing nuts</li> <li>- 8 screws + nuts</li> </ul>



\* Tests carried out by an independent laboratory Eurofins.



## HOW DOES IT WORK ?

The **Protect** reproduces a phenomenon that exists in nature: ionization. In natural spaces, the air is ionized and balanced between positive and negative ions.

unstable condition. In order to **stabilize**, these **bipolar ions seek out atoms and molecules in the air** to exchange electrons with, effectively **neutralizing particles, bacteria, virus cells, VOCs, gases and odorous aerosols**.



Thanks to cold plasma technology, the **Protect** is able to produce negative and positive ions. **Negative ions** contain an extra electron while **positive ions** lack an electron, resulting in an

**The airborne particles charged by the ions, gather and get stuck in the existing filters of the air conditioning systems. Bacteria and viruses bind to oxygen ions and are inactivated.** Many odorous gases and aerosols oxidize with oxygen ions and are neutralized.

## THE TECHNOLOGY

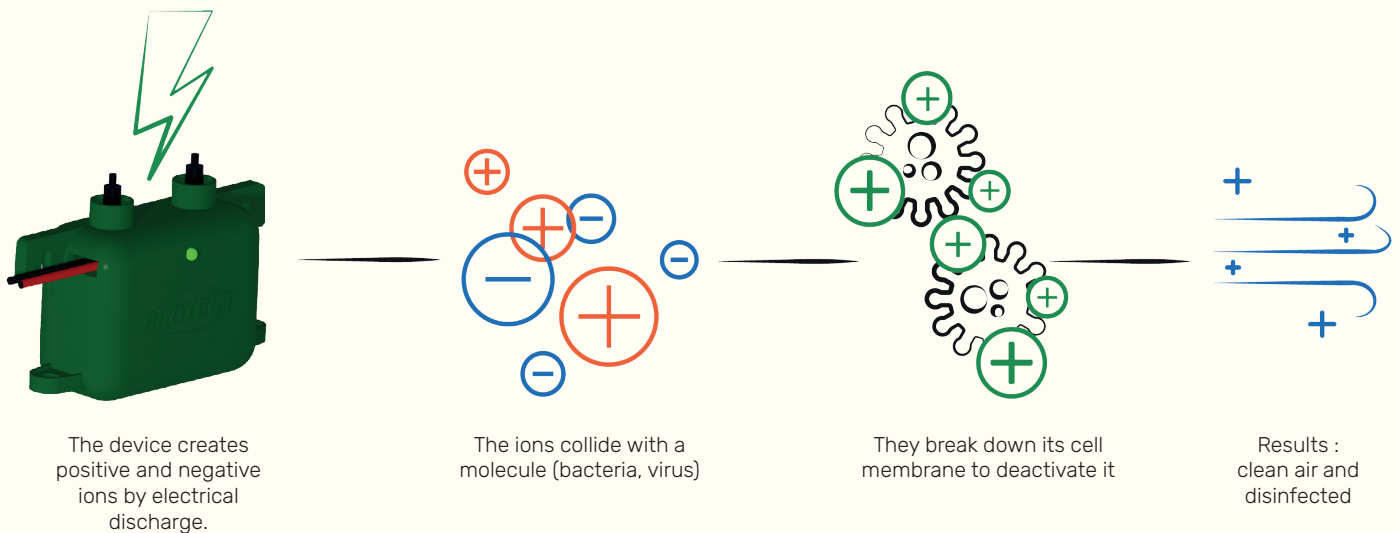

### SAFETY

To ensure maximum safety, a fuse is built into the device to protect it from power surges.



# INSTALLING *PROTECT*

A simple **3-step operation** allows the installation of the device, which once connected to the power supply, will offer you clean and disinfected air thanks to the *Protect*.

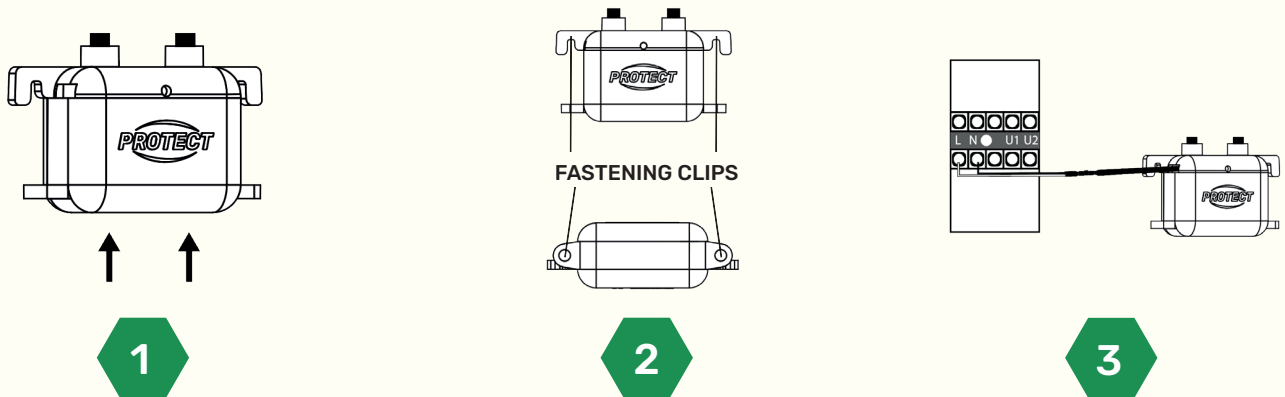

Place the module close to the air outlet so that the air flow passes over both brushes at the same time.

Secure the module using the four hooks located at the ends of the device.

Connect the appliance to the indoor unit respecting the appropriate voltage to the module.

## EASILY ADAPTS

**AIR CONDITIONER CASSETTE**

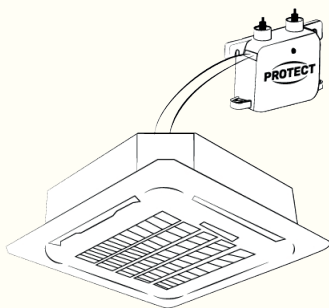

**WALL-MOUNTED AIR CONDITIONING**

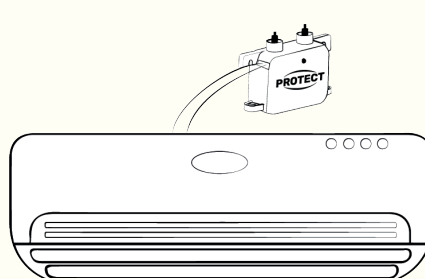

**CONVECTOR**

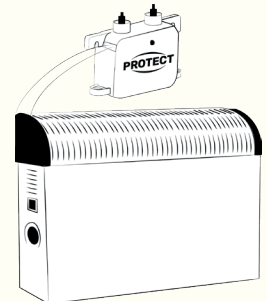

**REFRIGERATED TRUCK & CONTAINER**

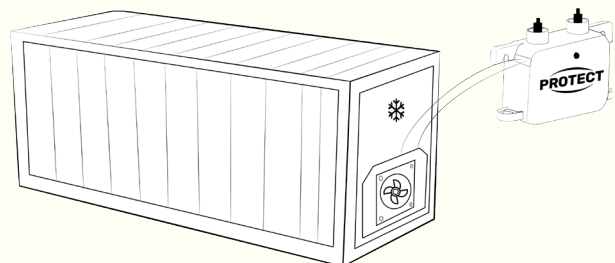
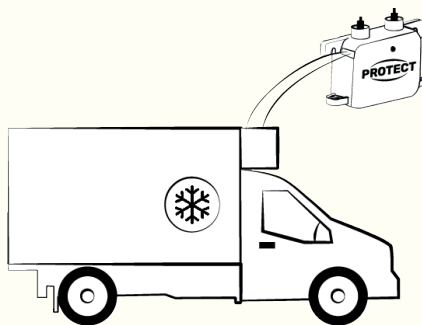

## MAINTENANCE

For optimal use, it is recommended to inspect the module brushes every 6 months to check for dust on them.





# PROTECT

Purifies your air

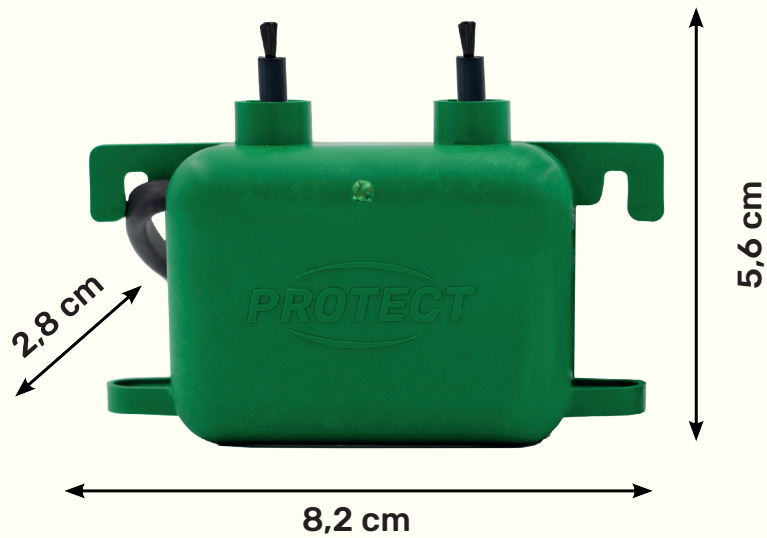

<b>Dimensions (LxHxW)</b>	8,2 cm x 5,6 cm x 2,8 cm
<b>Coverage area</b>	1000m <sup>3</sup> /h
<b>Weight</b>	120g
<b>Power supply</b>	AC 220V
<b>Power</b>	1,6 W
<b>Operating temperature</b>	from -10° to 55°C
<b>IP</b>	IP44 (For product shell)
<b>Bacteria*</b>	Staphylococcus Aureus
<b>Mold*</b>	Aspergillus brasiliensis
<b>Warranty</b>	2 years
<b>Comes with</b>	- 1 user manual - 1 power cable (1m50) - 1 certification label

\* Tests carried out by an independent laboratory Eurofins.

# WHERE ARE NEGATIVE IONS FOUND ?

Negative ions are present everywhere in the ambient air in varying quantities. However, thanks to our purification modules, you can experience a feeling of healthy air and well-being directly in your home !

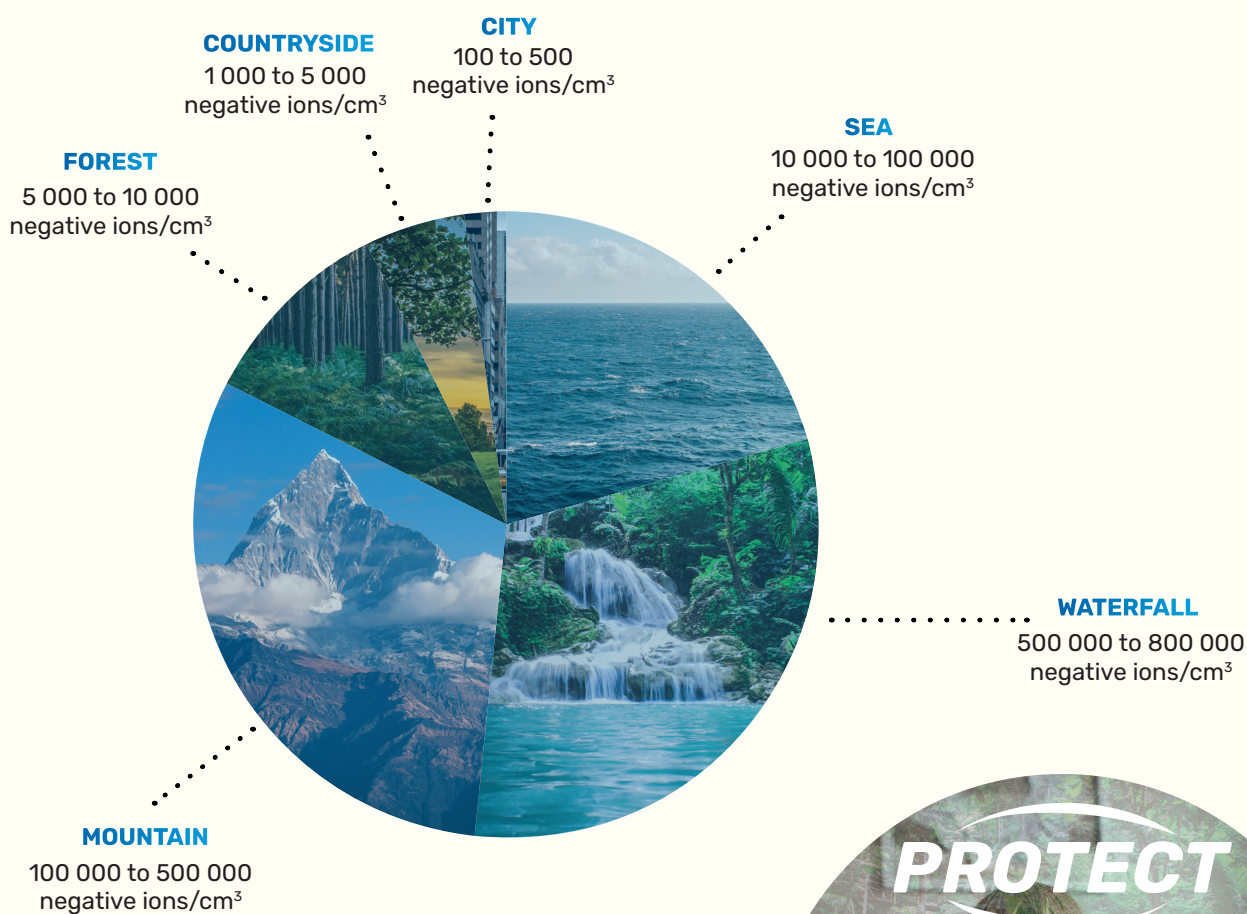

**PROTECT DEFENDER<sup>7</sup>**

Our two modules generate 30 million negative ions per cm<sup>3</sup>.



Transform your living spaces into pure and natural environments.



# THE BENEFITS OF NEGATIVE IONS

Negative ions are both beneficial to psychic and biological functions. They interact directly with the airways and through the skin and promote exchanges between the cells of our body.



## HEALTH\*

Negative ions improve the **general state of health** because they promote **better penetration of oxygen** into the lungs. **Better oxygenation** will influence **heart function, blood flow velocity, and sleep quality**. They also stimulate **enzymes and hormones** that help **strengthen the immune system**.



## WELL-BEING\*

By **reducing serotonin levels**, negative ions **improve concentration and memory and reduce feelings of fatigue or mood swings**. So you get a feeling of well-being.



## FIGHT AGAINST FINE PARTICLES\*

**Ionization is effective in depolluting interior spaces**. By spreading through the air, negative ions **prevent harmful particles** (pollen, germs, Volatile Organic Compounds) from developing. **Thus people suffering from asthma or allergies see their condition improve**.

\* «Les bienfaits des ions négatifs», author Teqoya, [www.Teqoya.fr](http://www.Teqoya.fr).

\* «Quels sont les bienfaits des ions négatifs sur la santé ?», author airvia medical.



# MonaAir ADAPTS TO YOUR NEEDS

MonaAir devices apply for **different uses and environments** :



## HOMES AND OFFICES

Homes and offices can be polluted in various ways. However, MonaAir modules ensure a healthy environment thanks to their disinfection and purification capabilities.

## PUBLIC AND COLLECTIVE PLACES

MonaAir devices purify the indoor air of various public structures (daycares, schools, healthcare centers, cinemas, etc.) against viruses, molds, and pollutants, thus providing protection for frequented spaces.



## HOTELS AND RESTAURANTS

Our modules eliminate bacteria, viruses, and odors, reduce pollution, allergens, and dust to improve the well-being of customers in these spaces by providing a healthy environment.

## TRANSPORT AND SHOPS

Our compact and ergonomic devices can also be used in passenger and cargo transport to reduce airborne viral and bacterial contaminations and neutralize pollution from internal air conditioning systems.



## INDUSTRIES

Our air treatment technology solution neutralizes industrial chemical pollutants, providing protection for staff and improving their comfort.



## FOOD INDUSTRY AND AGRICULTURE

Our air purification systems limit bacterial degradation during storage without chemicals, thus ensuring better food quality.





# COMPARISON OF CLEANSING TECHNOLOGIES

			HEPA Filter	Activated carbon filter	Ozone Machine
 Antivirus and Antibacterial	✓	✓	✗	✗	✓
 Human presence operation	✓	✓	✓	✓	✗
 Air purification	✓	✓	✓	✓	✗
 Ecological	✓	✓	✗	✗	✗
 Eliminates odors	✓	✓	✓	✓	✓
 Blocks bacterial growth	✓	✓	✗	✗	✓
 Silent	✓	✓	✗	✓	✓
 Easy maintenance	✓	✓	✗	✓	✗



MonaAir is a brand manufactured and distributed by **GPS Monaco Group**, a company approved by the **Monaco Department of Health** for the sale of medical devices, biocides for human use, Personal Protective Equipment (PPE), cleaning and disinfection products.









# THE BENEFITS OF *McnaAir*





# MonaAir

Technology At The Service Of Your Air



Do you want more specific information ?  
Contact us !

**Patrick Bogaerts**

**Email :** Patrick@MonaAir.com

**Phone :** +377 99 99 07 00 / 06 07 93 79 98



[www.MonaAir.com](http://www.MonaAir.com)