

PRODUCT SHEET



2 years warranty

Due to its **unique design**, our purifier **disinfects your interior spaces, purifies the air** and **improves your daily life** by reproducing a natural phenomenon : **ionization**.



TECHNICAL CHARACTERISTICS

Product reference	PR0002640
Coverage area	1000m ³ /h
Weight	120g
Power supply	AC 220V
Power	1,6 W
Operating temperature	de -10° à 55°C
IP	IP44 (For product shell)
Bacteria*	Staphylococcus Aureus
Mold*	Aspergillus brasiliensis
Comes with	- 1 user manual - 1 power cable (1m50) - 1 certification label

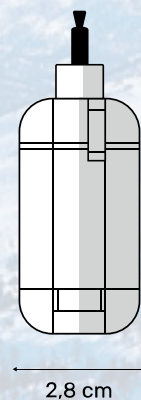
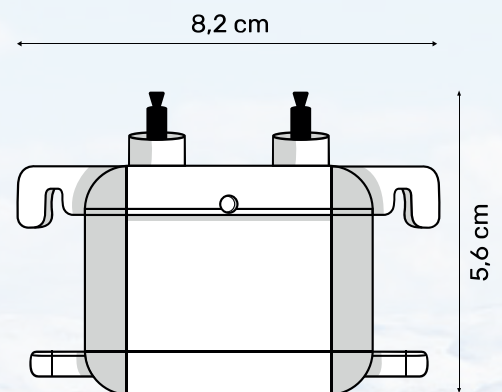

* Tests carried out by an independant laboratory, Eurofins.



INSTALLATION

The **Protect** module is easily installed in 3 steps and adapts to all existing types of air conditioning such as cassette air conditioning, wall-mounted, convectors, refrigerated trucks and refrigerated containers.

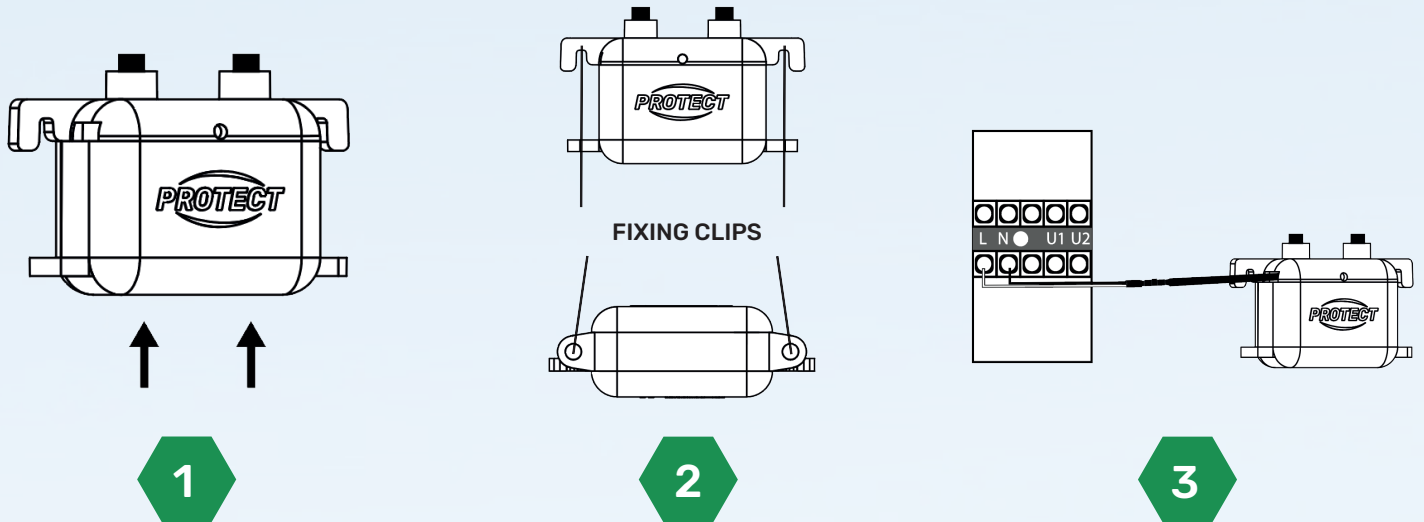

1

Place the module near the air outlet so that the flow passes simultaneously between the two brushes.

2

Depending on the device, fix the module using the hooks located at its ends.

It is not mandatory to use the four hooks because our module adapts to your installation.

3

Connect the appliance to the indoor unit, respecting the appropriate voltage to the module.

ADAPTATION

AIR CONDITIONER CASSETTE

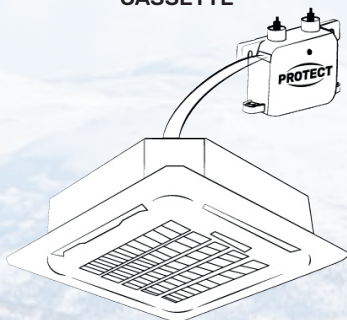

WALL-MOUNTED AIR CONDITIONING



CONVECTOR



REFRIGERATED TRUCK

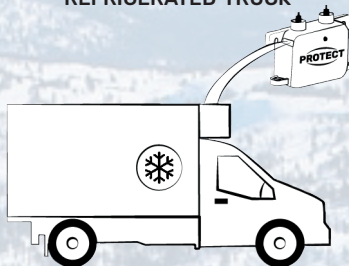

REFRIGERATED CONTAINER

